

TIP PROJECT: HS-2406N

CONTRACT: DF00543

STATE OF NORTH CAROLINA
DIVISION OF HIGHWAYS

BLADEN COUNTY

LOCATION: NC 87 AT NC 131

TYPE OF WORK: *INSTALL TRAFFIC SIGNAL.*

STATE	STATE PROJECT REFERENCE NO.	SHEET NO.	TOTAL SHEETS
N.C.	HS-2406N	1	
STATE PROJ. NO.	F. A. PROJ. NO.	DESCRIPTION	
50978.1.15	5097814	PE	
50978.2.15	5097814	ROW	
50978.2.25	5097814	UTL	
50978.3.15	5097814	CON	

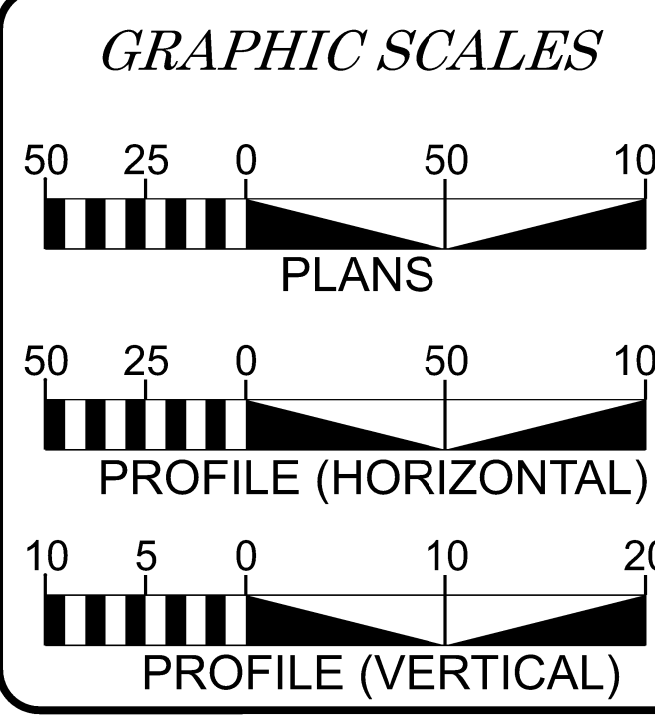
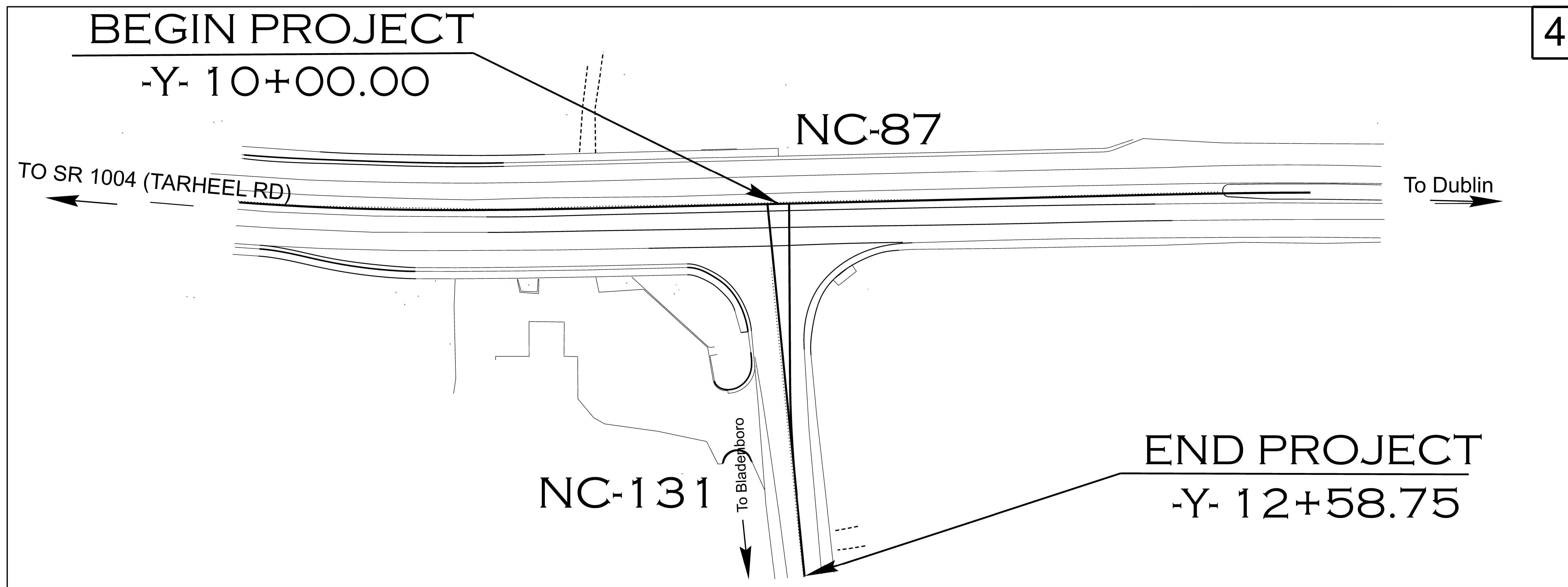
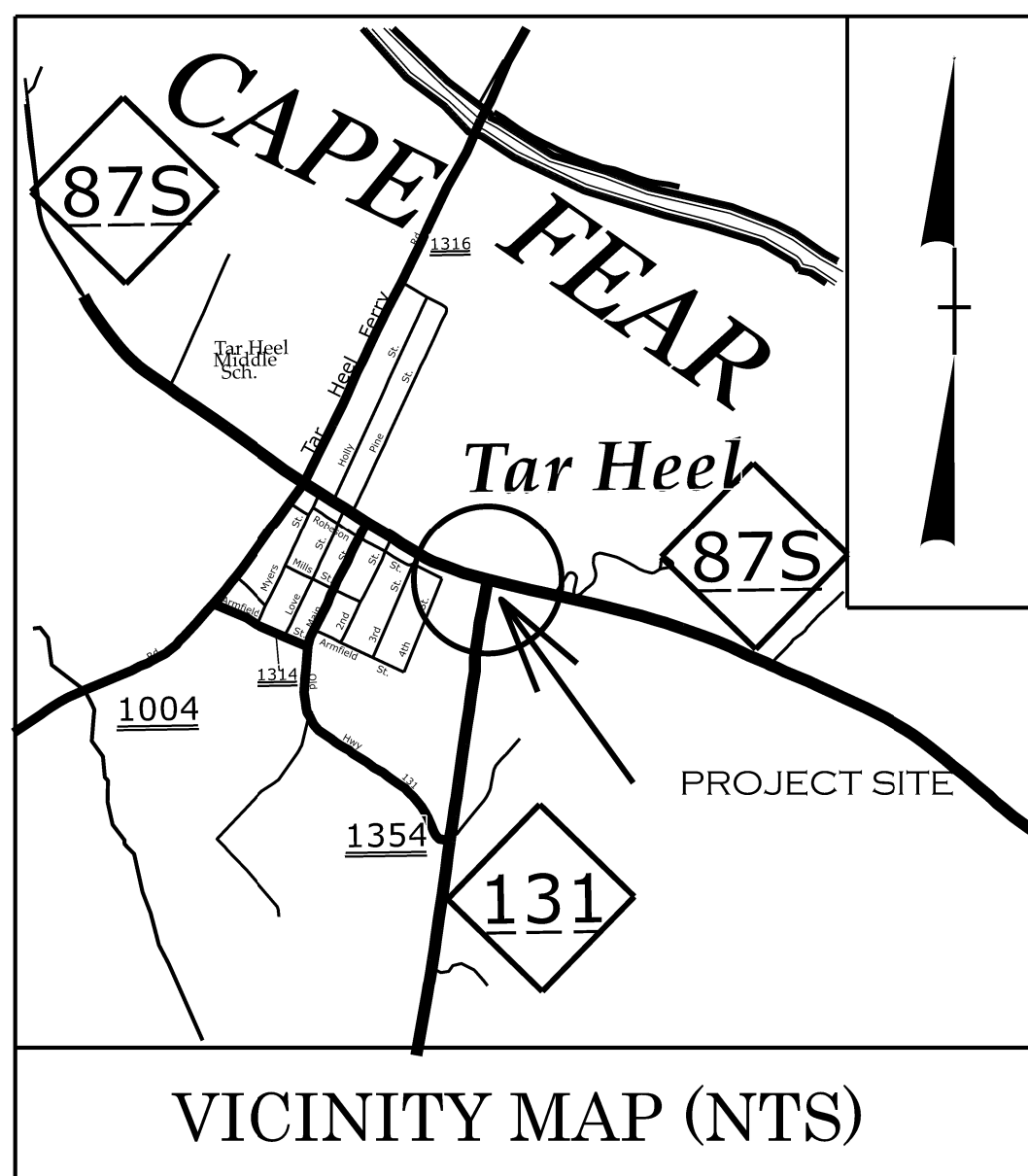
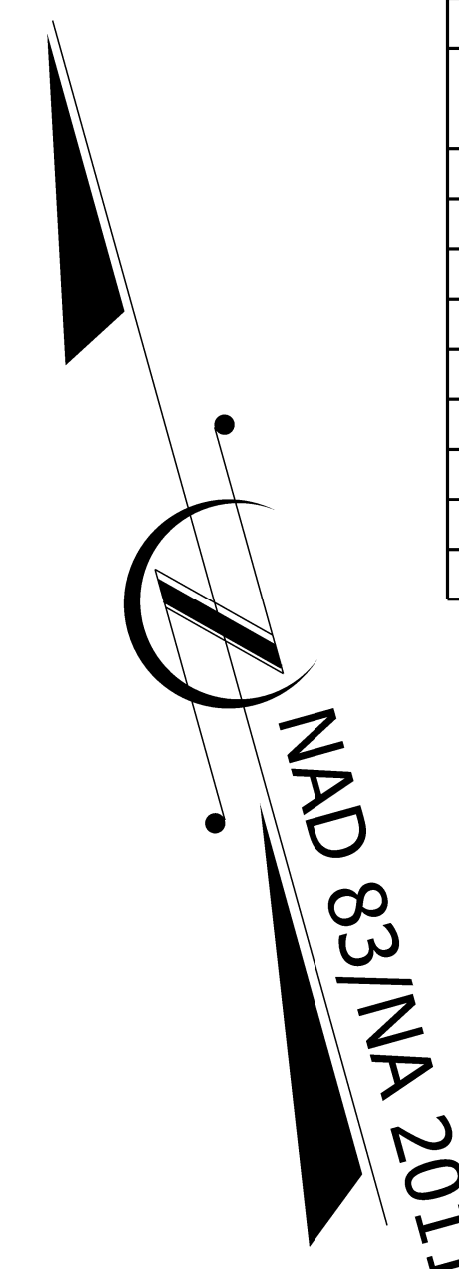

DESIGN DATA
 ADT 2023 = 3200
 ADT 2045 = 4700

Prepared in the Office of:
DIVISION OF HIGHWAYS
 431 Transportation Dr., Fayetteville NC, 28306

2024 STANDARD SPECIFICATIONS

RIGHT OF WAY DATE:
MAY 7, 2025

LETTING DATE:
February 4, 2026

JOHN GAUTHIER
PROJECT ENGINEER

B.K. MATTHEWS
PROJECT DESIGN ENGINEER

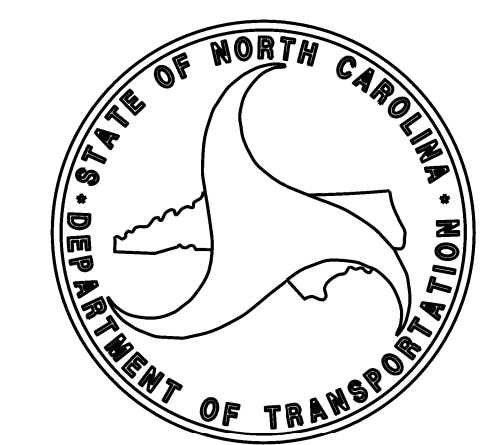

HS-2406N

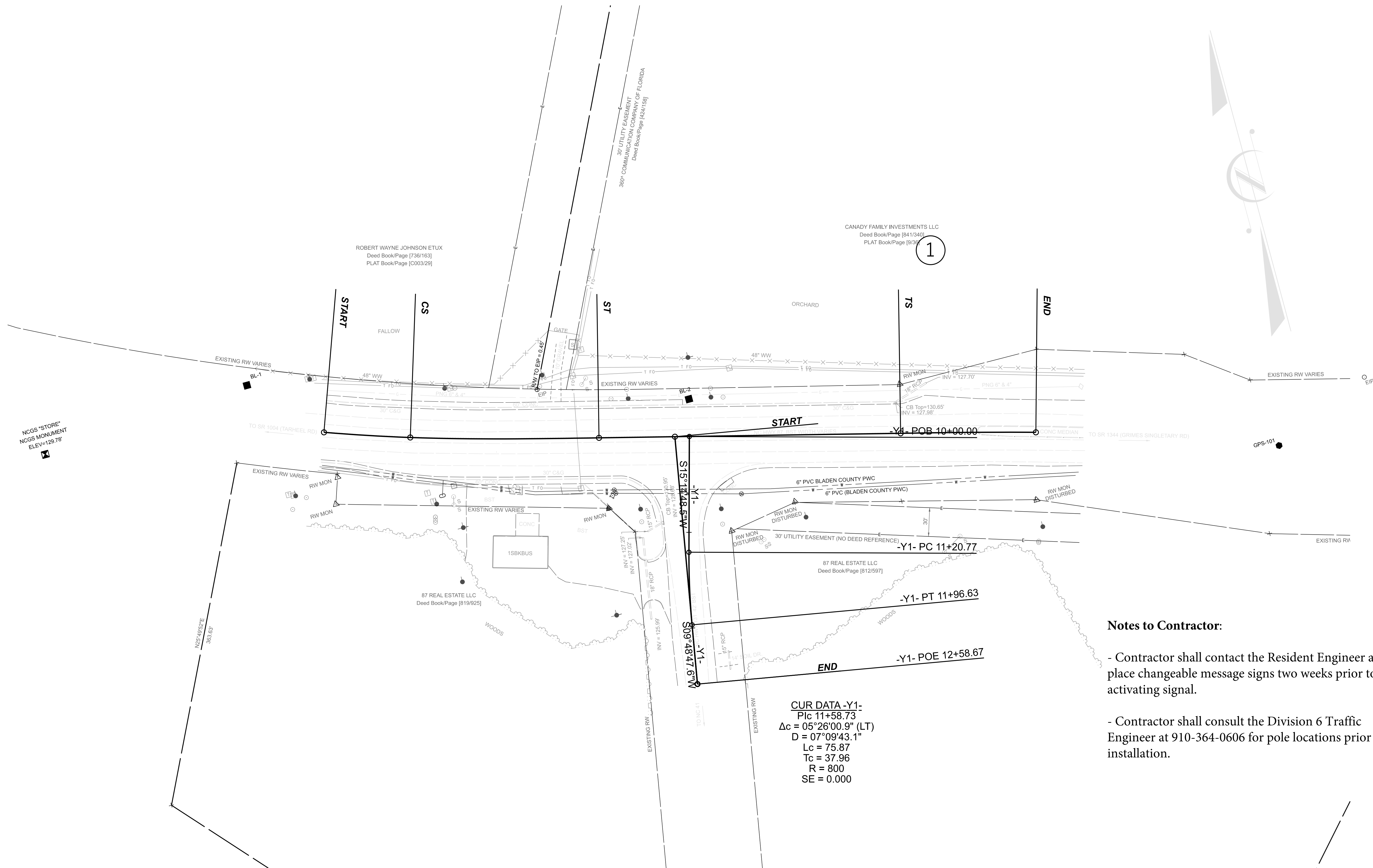

CUR DATA -Y1-
 Plc 11+58.73
 $\Delta c = 05^{\circ}26'00.9''$ (LT)
 $D = 07^{\circ}09'43.1''$
 $Lc = 75.87$
 $Tc = 37.96$
 $R = 800$
 $SE = 0.000$

Notes to Contractor:

- Contractor shall contact the Resident Engineer and place changeable message signs two weeks prior to activating signal.
- Contractor shall consult the Division 6 Traffic Engineer at 910-364-0606 for pole locations prior to installation.

18 CHANNEL CONFLICT MONITOR PROGRAMMING DETAIL

(remove jumpers and set switches as shown)

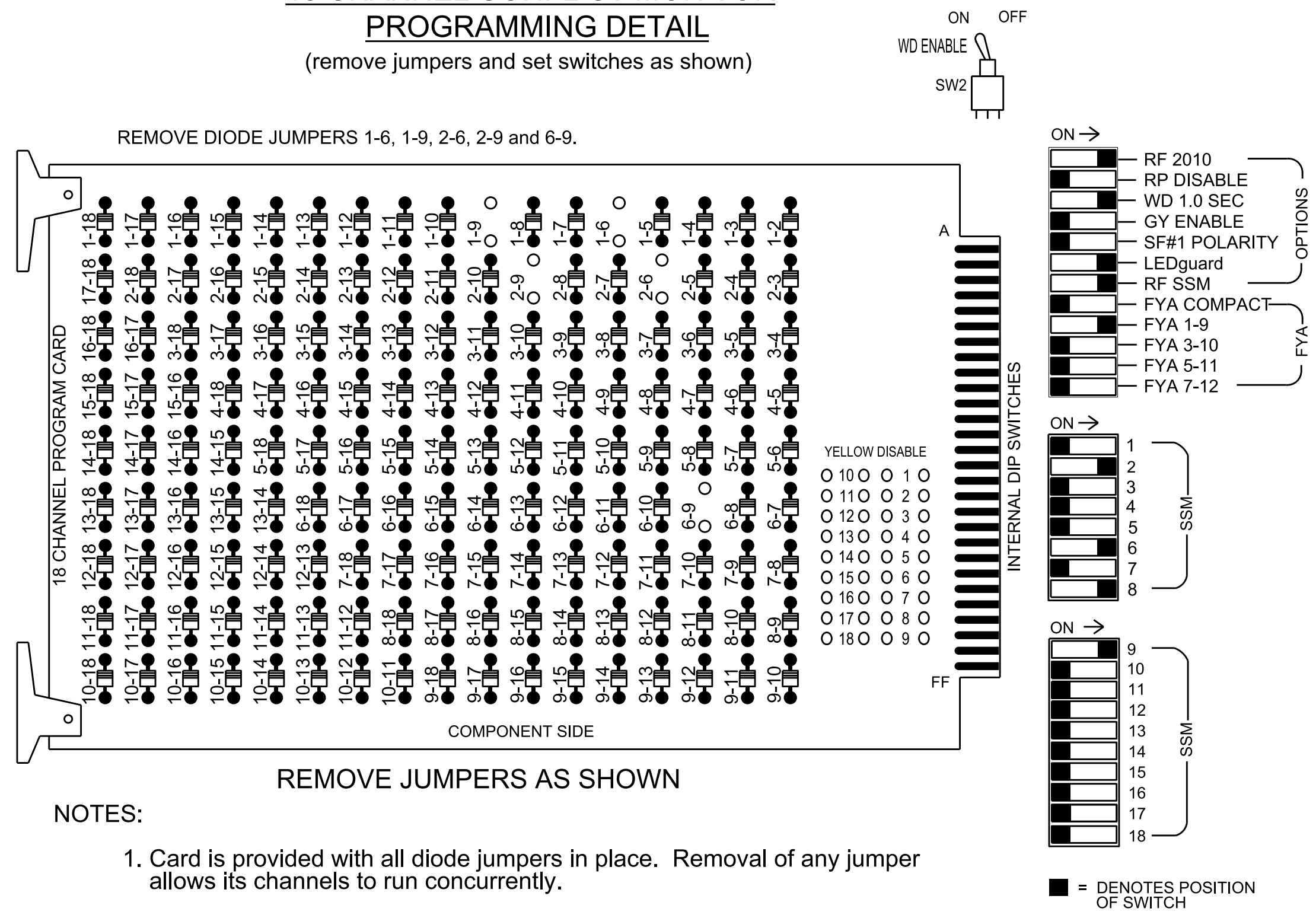

NOTES:

- Card is provided with all diode jumpers in place. Removal of any jumper allows its channels to run concurrently.
- Ensure jumpers SEL2-SEL5 and SEL9 are present on the monitor board.
- Ensure that the Red Enable is active at all times during normal operation.
- Connect serial cable from conflict monitor to comm. port 1 of 2070 controller. Ensure conflict monitor communicates with 2070.

NOTES

- To prevent "flash-conflict" problems, insert red flash program blocks for all vehicle load switches in the output file. The installer shall verify that signal heads flash in accordance with the signal plan.
- Program controller to start up in phase 2 Green No Walk and 6 Green No Walk.
- If this signal will be managed by an ATMS software, enable controller and detector logging for all detectors used at this location.

EQUIPMENT INFORMATION

Controller.....2070LX
 Cabinet.....332 w/ Aux
 Software.....Q-Free MAXTIME
 Cabinet Mount.....Base
 Output File Positions.....18 With Aux. Output File
 Load Switches Used.....S1, S2, S8, S11, AUX S1
 Phases Used.....1, 2, 6, 8
 Overlap "1".....*
 Overlap "2".....Not Used
 Overlap "3".....Not Used
 Overlap "4".....Not Used

*See overlap programming detail on sheet 2

SIGNAL HEAD HOOK-UP CHART

LOAD SWITCH NO.	S1	S2	S3	S4	S5	S6	S7	S8	S9	S10	S11	S12	AUX S1	AUX S2	AUX S3	AUX S4	AUX S5	AUX S6
CMU CHANNEL NO.	1	2	13	3	4	14	5	6	15	7	8	16	9	10	17	11	12	18
PHASE	1	2	2 PED	3	4	4 PED	5	6	6 PED	7	8	8 PED	OL1	OL2	SPARE	OL3	OL4	SPARE
SIGNAL HEAD NO.	11*	21,22	NU	NU	NU	NU	NU	61,62	NU	NU	22	81,82	NU	11*	NU	NU	NU	NU
RED		128						134			107							
YELLOW	*	129						135			108							
GREEN		130						136			109							
RED ARROW													A121					
YELLOW ARROW										108			A122					
FLASHING YELLOW ARROW													A123					
GREEN ARROW	127										109							
Hand icon																		
Walking person icon																		

NU = Not Used
 * Denotes install load resistor. See load resistor installation detail this sheet.
 * See pictorial of head wiring in detail this sheet.

INPUT FILE POSITION LAYOUT

(front view)

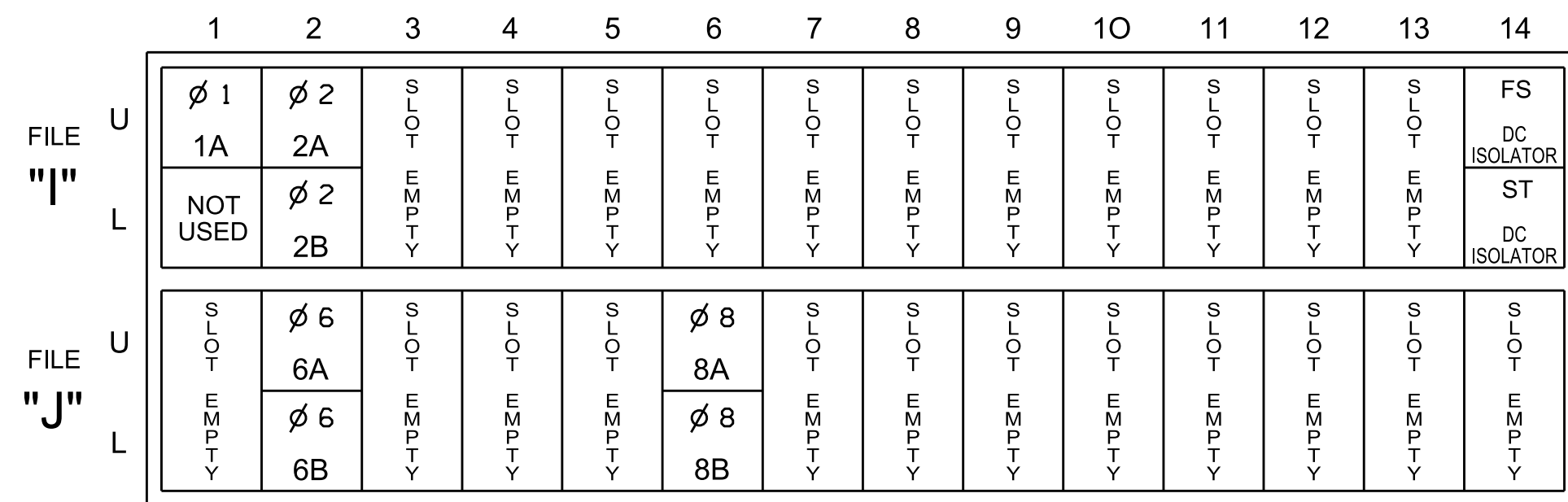

EX. : 1A, 2A, ETC. = LOOP NO.'S

FS = FLASH SENSE
 ST = STOP TIME

INPUT FILE CONNECTION & PROGRAMMING CHART

LOOP NO.	LOOP TERMINAL	INPUT FILE POS.	PIN NO.	INPUT POINT	DETECTOR NO.	CALL PHASE	DELAY TIME	EXTEND TIME	EXTEND	ADDED INITIAL	CALL	DELAY DURING GREEN
1A	TB2-1,2	I1U	56	18	1	1	15		X		X	
				-	29	6	3		X		X	X
2A	TB2-5,6	I2U	39	1	2	2			X	X	X	
2B	TB2-7,8	I2L	43	5	3	2			X	X	X	
6A	TB3-5,6	J2U	40	2	16	6			X	X	X	
6B	TB3-7,8	J2L	44	6	17	6			X	X	X	
8A	TB5-9,10	J6U	42	4	22	8			X	X	X	
8B	TB5-11,12	J6L	46	8	23	8	15		X		X	

INPUT FILE POSITION LEGEND: J2L

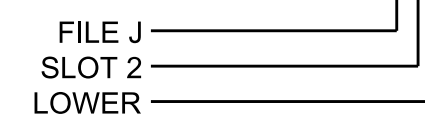

FYA SIGNAL WIRING DETAIL

(wire signal head as shown)

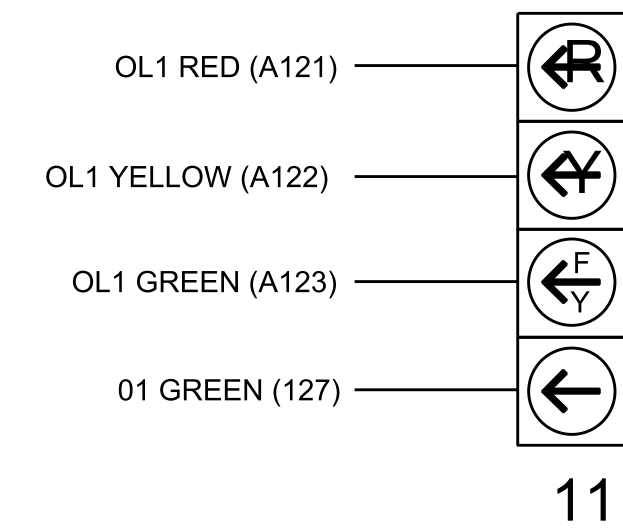

LOAD RESISTOR INSTALLATION DETAIL

(install resistor as shown)

ACCEPTABLE VALUES	
Value (ohms)	Wattage
1.5K - 1.9K	25W (min)
2.0K - 3.0K	10W (min)

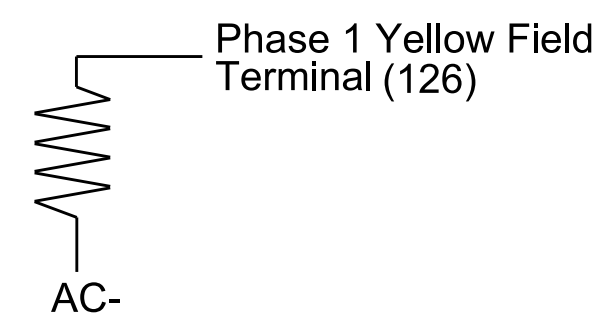

THIS ELECTRICAL DETAIL IS FOR THE SIGNAL DESIGN: 06-0873
 DESIGNED: December 2024
 SEALED: 1/13/2025
 REVISED: N/A

Electrical Detail - Sheet 1 of 2

Prepared in the Offices of:

 750 N. Greenfield Pkwy, Garner, NC 27529

NC 87
 at
 NC 131
 Division 6 Bladen County Near Tarheel
 PLAN DATE: January 2025 REVIEWED BY:
 PREPARED BY: Zarrar Zafar REVIEWED BY:
 REVISIONS INIT. DATE

DOCUMENT NOT CONSIDERED FINAL UNLESS ALL SIGNATURES COMPLETED
 SEAL

 SEAL 031001
 ENGINEER TODD JOYCE
 DocuSigned by: 01/14/2025
 DATE
 SIG. INVENTORY NO. 06-0873

